

DF-2 GAS

TRAIN

10/09/2012

BILL OF MATERIALS

ITEM NUMBER	Description	Quantity
1	1" Quick Seal	1
2	1" x 4" Nipple	1
3	1" 90° Elbow	2
4	1" Close Nipple (1-1/2")	4
5	1" Union	3
6	1" x 1" x 1/4" Tee	2
7	-5-15 w.c. Gas Pressure Gauge	1
8	1" x 2" Nipple	4
9	Robertshaw 7000DERHC 1" Combination Valve	1
10	Maxitrol M611 1" Modulating Valve	1
11	1" Manual Ball Valve	1
12	1" x 5" Nipple	1
13	1" x 8" Nipple	1
14	6", 12" or 18" Dual Fuel Midco Burner	1
15	1-1/2" to 1" 90° Reducing Elbow	1
16	1-1/2" Close Nipple (1-3/4")	1
17	0-35" w.c. Gas Pressure Gauge	1

Standard Gas Train

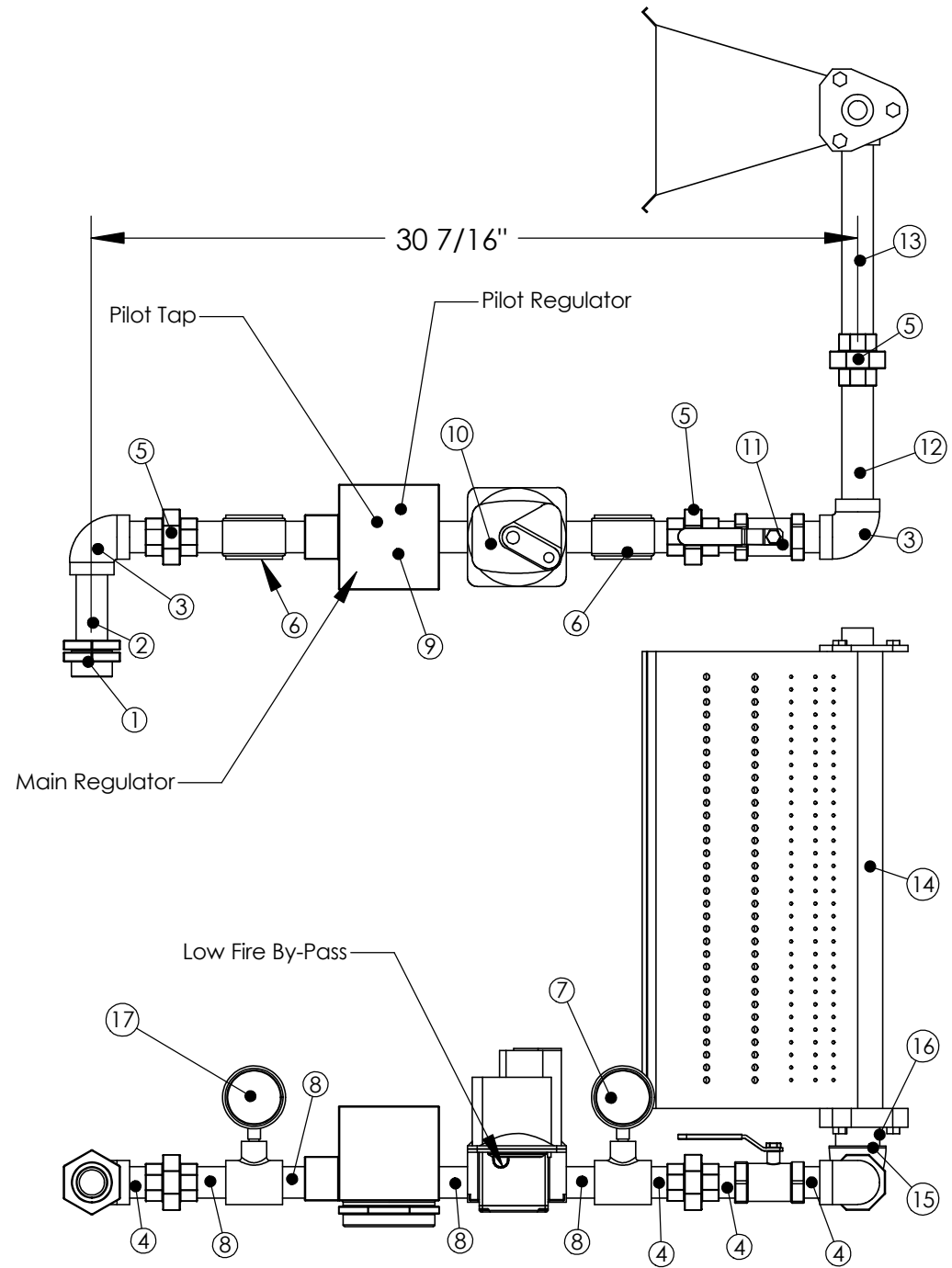

NOTES:
 Gas Type: Natural or LP
 Inlet Pressure: 7 in. w.c. - 14 in. w.c.
 Max. Natural Gas Manifold Pressure: 5 in. w.c.
 Max. LP Manifold Pressure: 2.5 in. w.c.

External High Gas Pressure Regulator Required when
 gas pressure exceeds 14 in. w.c.:
 P/N = 143-80-2-1-G-5/8 (10 psi. max.)

Material: N/A
 Blank Size: N/A x N/A
 Weight: N/A lbs

Part Number: N/A
 MACOLA/AX Number:
 Drawing Name: DF 2 Gas Train
 Drawn By: BRH
 Parent Assembly: DF 2
 Sheet: 2 of 5

Unless Otherwise Specified
 Dimensions are in Inches.
 Standard Tolerances are:
 Fractions: ±1/16
 Decimal: .XX±.05
 .XXX±.015
 Angles: ±1°

CONFIDENTIAL

BILL OF MATERIALS

ITEM NUMBER	Description	Quantity
1	1" Quick Seal	1
2	1" x 4" Nipple	1
3	1" 90° Elbow	2
4	1" Close Nipple (1-1/2")	4
5	1" Union	3
6	1" x 1" x 1/4" Tee	2
7	1/4" Square Head Pipe Plug	2
8	1" x 2" Nipple	4
9	Robertshaw 7000DERHC 1" Combination Valve	1
10	Maxitrol M611 1" Modulating Valve	1
11	1" Manual Ball Valve	1
12	1" x 5" Nipple	1
13	1" x 8" Nipple	1
14	6", 12" or 18" Dual Fuel Midco Burner	1
15	1/4" Close Nipple (1")	4
16	1/4" x 1/4" x 1/4" Tee	2
17	Optional Antunes HGP-A M1 Pressure Switch	1
18	Optional Antunes LGP-A M1 Pressure Switch	1
19	1-1/2" to 1" 90° Reducing Elbow	1
20	1-1/2" Close Nipple (1-3/4")	1

Gas Train w/Pressure Switch

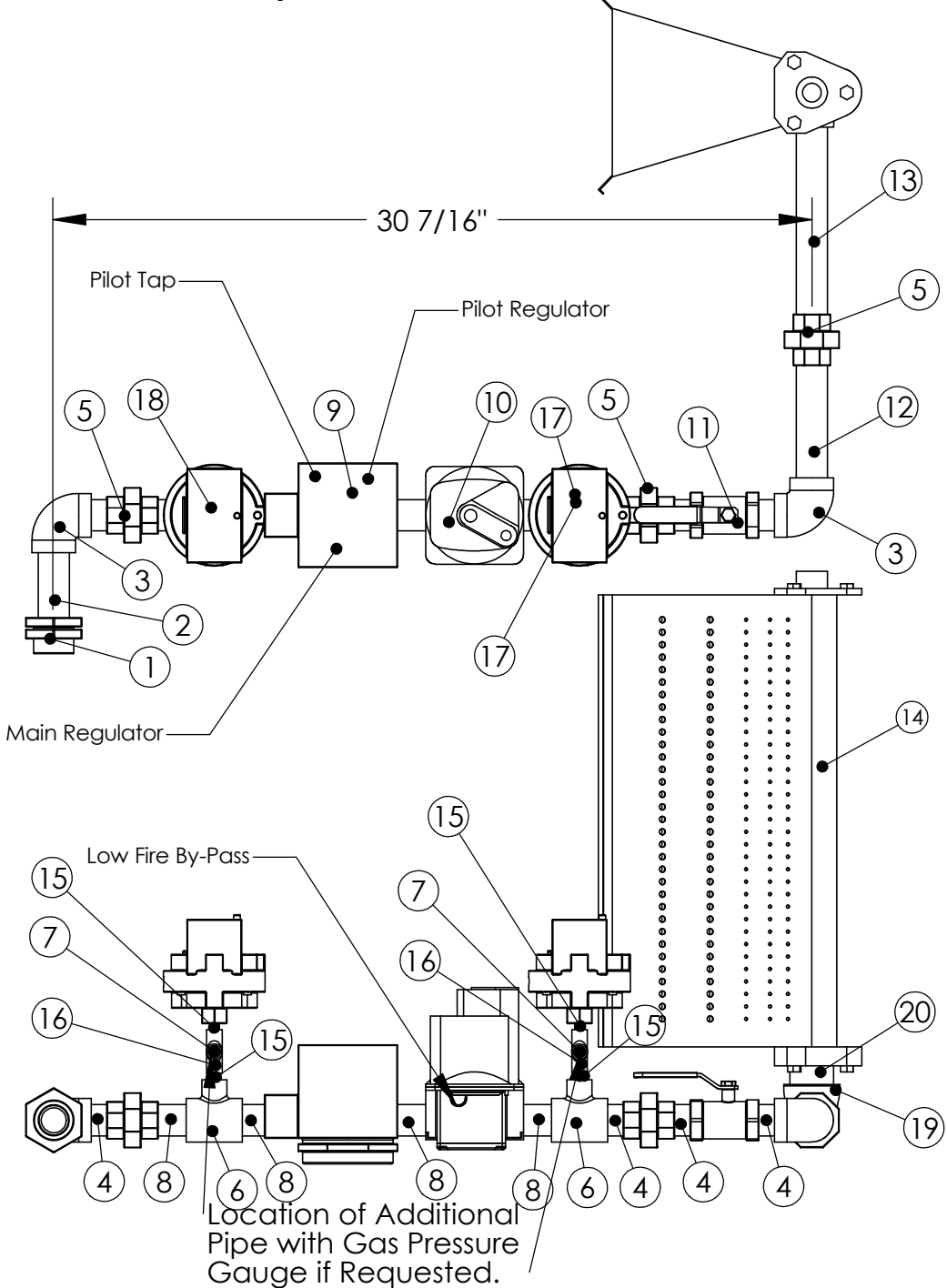

NOTES:
 Gas Type: Natural or LP
 Inlet Pressure: 7 in. w.c. - 14 in. w.c.
 Max. Natural Gas Manifold Pressure: 5 in. w.c.
 Max. LP Manifold Pressure: 2.5 in. w.c.

External High Gas Pressure Regulator Required when gas pressure exceeds 14 in. w.c.:
 P/N = 143-80-2-1-G-5/8 (10 psi. max.)

Material: N/A
 Blank Size: N/A x N/A
 Weight: N/A lbs

Part Number: N/A
 MACOLA/AX Number:
 Drawing Name: DF 2 Gas Train
 Drawn By: BRH
 Parent Assembly: DF 2
 Sheet: 3 of 5

Unless Otherwise Specified
 Dimensions are in Inches.
 Standard Tolerances are:
 Fractions: ±1/16
 Decimal: .XX±.05
 .XXX±.015
 Angles: ±1°

CONFIDENTIAL

BILL OF MATERIALS

ITEM NUMBER	Description	Quantity
1	1" Quick Seal	1
2	1" x 4" Nipple	1
3	1" 90° Elbow	2
4	1" Close Nipple (1-1/2")	4
5	1" Union	3
6	1" x 1" x 1/4" Tee	2
7	-5-15 w.c. Gas Pressure Gauge	1
8	1" x 2" Nipple	4
9	Robertshaw 7000DERHC 1" Combination Valve	1
10	Maxitrol M611 1" Modulating Valve	1
11	1" Manual Ball Valve	1
12	1" x 5" Nipple	1
13	1" x 8" Nipple	1
14	6", 12" or 18" Dual Fuel Midco Burner	1
15	1/4" Close Nipple (1")	3
16	1/4" x 1/4" x 1/4" Tee	1
17	1/4" x 3" Nipple	1
18	1/4" 90 Elbow	0
19	1-1/2" to 1" 90° Reducing Elbow	1
20	1-1/2" Close Nipple (1-3/4")	1
21	0-35" w.c. Gas Pressure Gauge	1
22	RV20LW-22-0002 1/4" Regulator	1
23	1/4" Manual Ball Valve	1
24	V4046C1021 Solenoid Valve	1
25	1/4" Brass 90 Elbow	1

Gas Train w/Upstream Pilot

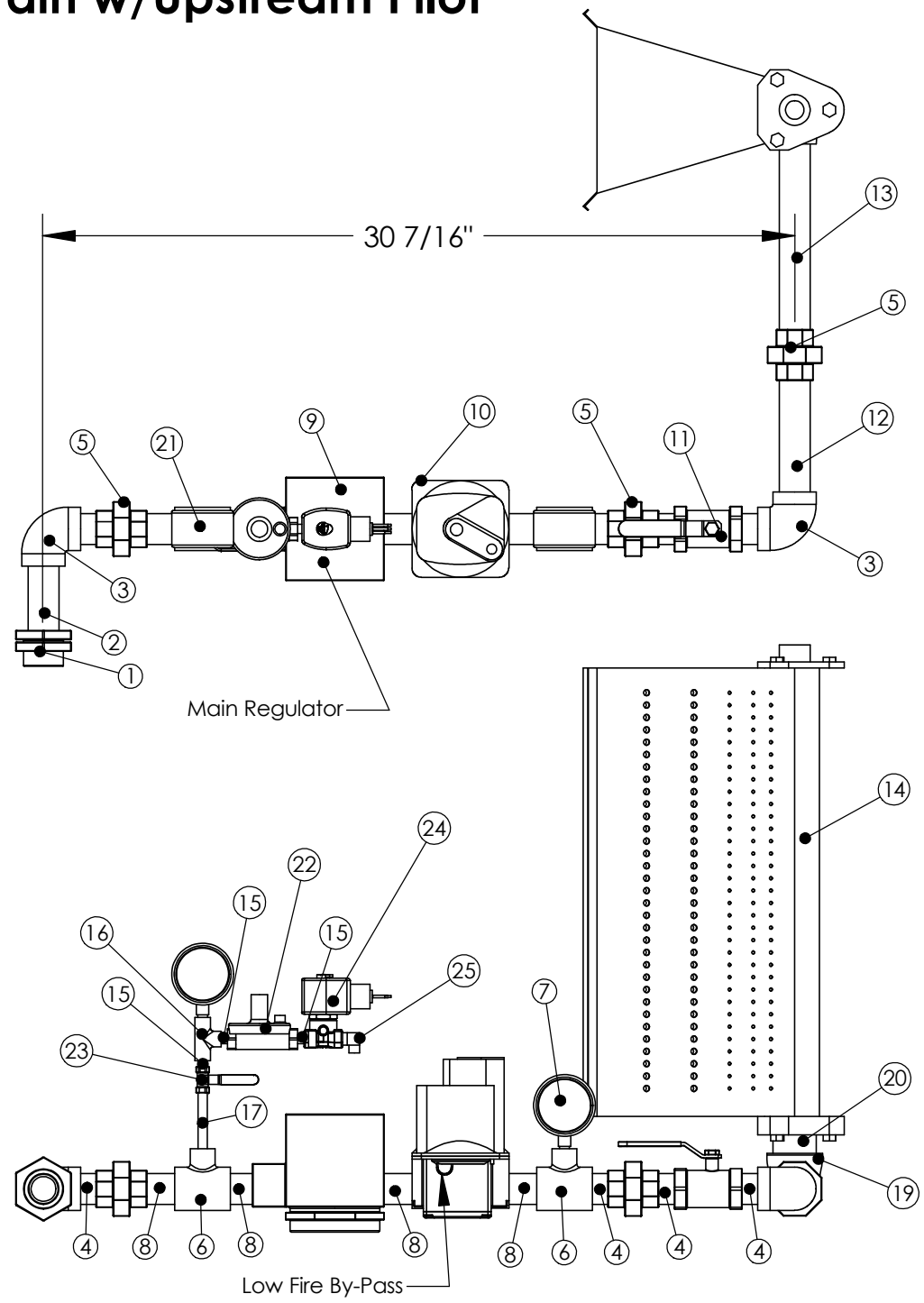

NOTES:
 Gas Type: Natural or LP
 Inlet Pressure: 7 in. w.c. - 14 in. w.c.
 Max. Natural Gas Manifold Pressure: 5 in. w.c.
 Max. LP Manifold Pressure: 2.5 in. w.c.

External High Gas Pressure Regulator Required when gas pressure exceeds 14 in. w.c.:
 P/N = 143-80-2-1-G-5/8 (10 psi. max.)

Material: N/A
 Blank Size: N/A x N/A
 Weight: N/A lbs

Part Number: N/A
 MACOLA/AX Number:
 Drawing Name: DF 2 Gas Train
 Drawn By: DDH
 Parent Assembly: DF 2
 Sheet: 4 of 5

Unless Otherwise Specified
 Dimensions are in Inches.
 Standard Tolerances are:
 Fractions: ±1/16
 Decimal: .XX±.05
 .XXX±.015
 Angles: ±1°

CONFIDENTIAL

BILL OF MATERIALS

ITEM NUMBER	Description	Quantity
1	1" Quick Seal	1
2	1" x 4" Nipple	1
3	1" 90° Elbow	2
4	1" Close Nipple (1-1/2")	4
5	1" Union	3
6	1" x 1" x 1/4" Tee	2
7	-5-15 w.c. Gas Pressure Gauge	1
8	1" x 2" Nipple	4
9	Robertshaw 7000DERHC 1" Combination Valve	1
10	Maxitrol M611 1" Modulating Valve	1
11	1" Manual Ball Valve	1
12	1" x 5" Nipple	1
13	1" x 8" Nipple	1
14	6", 12" or 18" Dual Fuel Midco Burner	1
15	1/4" Close Nipple (1")	8
16	1/4" x 1/4" x 1/4" Tee	3
17	1/4" 90 Elbow	2
18	1-1/2" to 1" 90° Reducing Elbow	1
19	1-1/2" Close Nipple (1-3/4")	1
20	0-35" w.c. Gas Pressure Gauge	1
21	1/4" x 3" Nipple	2
22	RV20LW-22-0002 1/4" Regulator	1
23	1/4" Manual Ball Valve	1
24	V4046C1021 Solenoid Valve	1
25	1/4" Brass 90 Elbow	1
26	Antunes LGP-A M1 Pressure Sw itch	1
27	Antunes HGP-A M1 Pressure Sw itch	1

Gas Train Upstream Pilot w/Pressure Switches

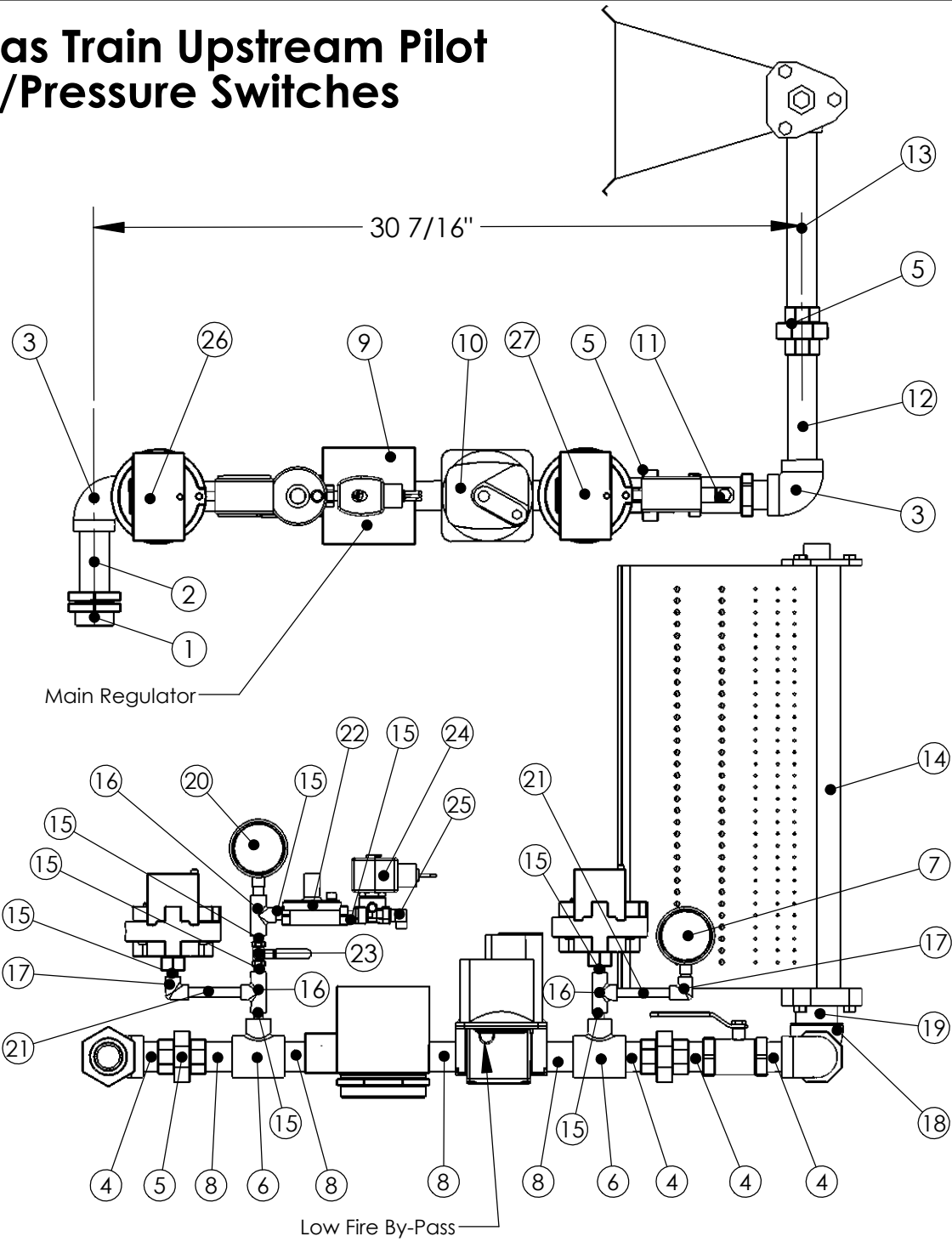

NOTES:
 Gas Type: Natural or LP
 Inlet Pressure: 7 in. w.c. - 14 in. w.c.
 Max. Natural Gas Manifold Pressure: 5 in. w.c.
 Max. LP Manifold Pressure: 2.5 in. w.c.

External High Gas Pressure Regulator Required when gas pressure exceeds 14 in. w.c.:
 P/N = 143-80-2-1-G-5/8 (10 psi. max.)

Material: N/A
 Blank Size: N/A x N/A
 Weight: N/A lbs

Part Number: N/A
 MACOLA/AX Number:
 Drawing Name: DF 2 Gas Train
 Drawn By: BRH
 Parent Assembly: DF 2
 Sheet: 5 of 5

Unless Otherwise Specified
 Dimensions are in Inches.
 Standard Tolerances are:
 Fractions: ±1/16
 Decimal: .XX±.05
 .XXX±.015
 Angles: ±1°

CONFIDENTIAL